

RCBS[®]

**CASE MASTER[™]
GAUGING TOOL**

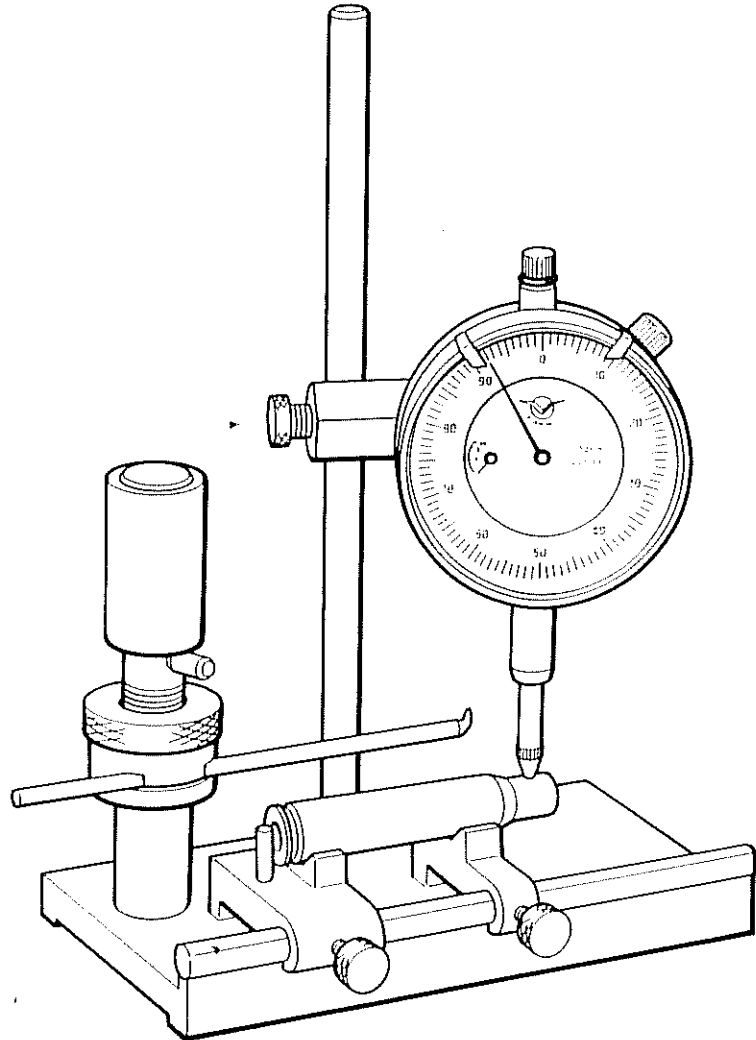

P R O D U C T I N S T R U C T I O N S

SAFETY

Reloading is an enjoyable and rewarding hobby that is easily conducted with safety. But carelessness or negligence can make reloading hazardous. This product has been designed from the beginning with the user's safety in mind. As with any reloading operation, some safety rules must be followed. By observing these few rules, the chance of a hazardous occurrence causing damage or injury becomes extremely remote.

GENERAL

- Use the reloading equipment as the manufacturer recommends. Study the instructions carefully and become thoroughly familiar with the operation of the product. Don't take short cuts.
- Observe "good housekeeping" in the reloading area. Keep tools and components neat, clean and orderly. Promptly and completely clean up primer and powder spills.
- Reload only when you can give your undivided attention. Do not reload when fatigued or ill. Develop a reloading routine to avoid mistakes. Avoid haste - load at a leisurely pace.
- Always wear adequate eye protection. You assume unnecessary risk when reloading without wearing safety glasses.

LOADING DATA

- Use only laboratory tested reloading data. We highly recommend the use of the SPEER Reloading Manual.
- OBSERVE ALL WARNINGS ABOUT THE USE OF MAXIMUM LISTED LOADS.

PRIMERS AND POWDER

- Store primers and powder beyond the reach of children and away from heat, dampness, open flames and electrical equipment.
- DO NOT use primers of unknown identity.
- Keep primers in original factory container until ready to use. Return unused primers to the same factory packaging for safety and to preserve their identity.
- DO NOT store primers in bulk. The blast of just a few primers is sufficient to cause serious injury to anyone nearby.
- DO NOT force primers. Use care in handling primers.
- DO NOT use any powder unless its identity is positively known. Discard all mixed powders and those of uncertain or unknown identity.
- If you use a powder measure, replace the lids on both the powder hopper and powder can after the powder hopper has been filled.
- Before charging cases, settle the powder in the powder hopper. Throw and check the weight of at least ten charges. This will assure you that the correct powder charge is being thrown.
- After a reloading session ends, pour the remaining powder back in its original factory container. This will preserve the identity and shelf life of the powder.
- DO NOT smoke while handling powder or primers.

RECORD KEEPING

- Keep complete records of reloads. Apply a descriptive label to each box showing the date produced, and the primer, powder and bullet used. Labels for this purpose are packed with SPEER bullets.

Since RCBS has no control over the choice of components, the manner in which they are assembled, the use of this product, or the firearms in which the resulting ammunition may be used, no responsibility, either expressed or implied, is assumed for the use of ammunition reloaded with this product.

General Information

Congratulations on your purchase of the RCBS CaseMaster™ gauging tool. This precision instrument allows the reloader to make a number of measurements of cases and loaded ammunition. These measurements include: Case neck run-out, bullet run-out, case neck thickness, cartridge length and case head separation. CaseMaster™ helps the reloader maximize the accuracy of his ammunition by fine-tuning the reloading process. Please read these instructions completely before using the CaseMaster™.

Shown below in photo #1 is a CaseMaster™ mounted to an RCBS Accessory Base Plate-2. Mounting the CaseMaster™ to a solid surface like the base plate gives the gauging tool added stability. Two lock down screws have been included with the CaseMaster™.

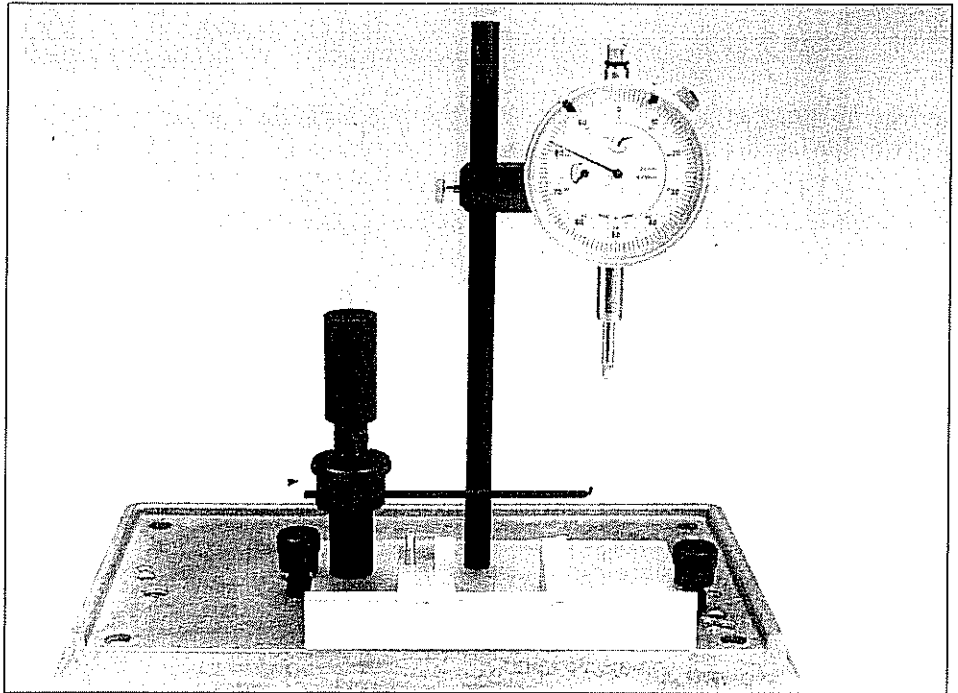
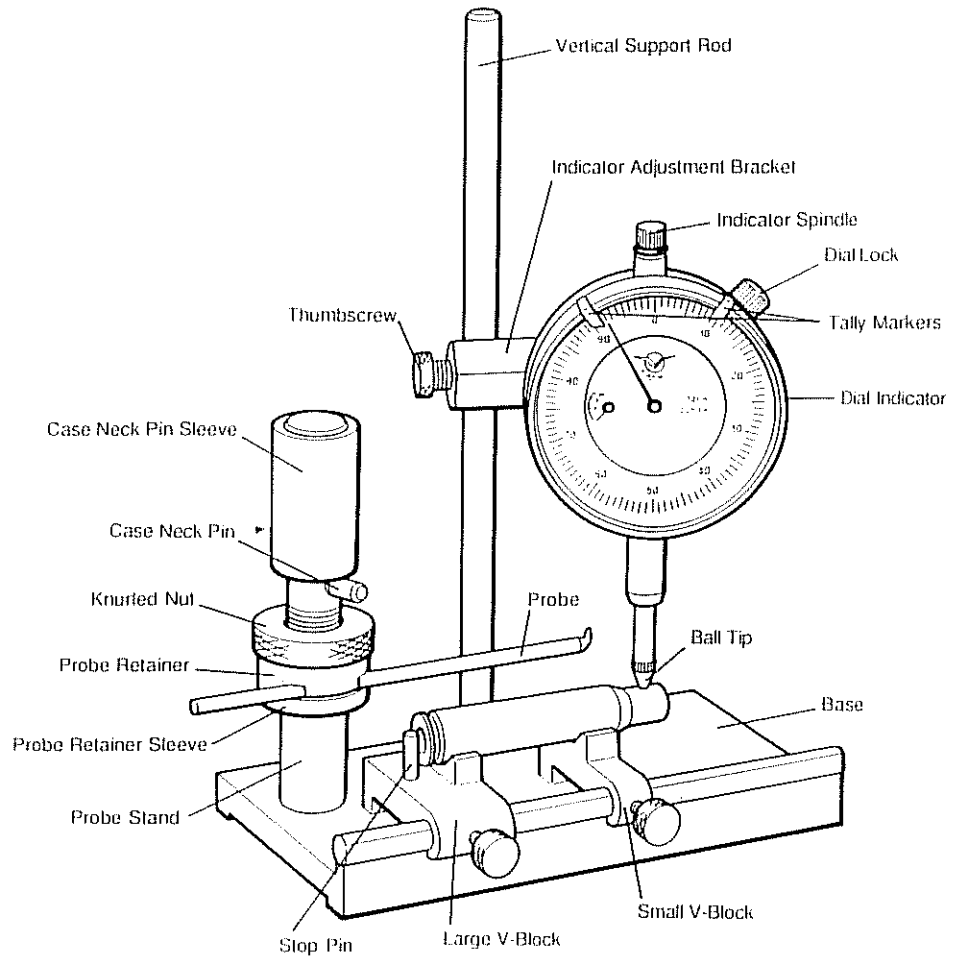

Photo #1

COMPONENTS DESCRIPTION



The Components of the CaseMaster™

Dial Indicator

The heart of the CaseMaster™ is a precision dial indicator. Because it is a delicate instrument, the dial indicator should be handled with care. This indicator is accurate to ± 0.001 inch, and has a travel of 0.250 inch (1/4 inch). The larger pointer reads from zero to 0.100 inch; a smaller pointer reads from zero to 0.250 inch.

The face of the outer dial can be rotated to zero the large pointer. Loosen the dial lock located at the two o'clock position on the body of the indicator. The dial can then be rotated to align the zero mark with the pointer tip. Tighten the knob to lock the setting.

The dial indicator is mounted to a vertical support rod with an indicator adjustment bracket. This bracket allows the indicator to be placed in the variety of positions needed for different types of measurements.

Two indicator tips are furnished. See photo #2. The ball tip is used for neck thickness, case head separation and run-out testing; the flat tip is used for case length measurements. To change tips, simply unscrew and install the other. NOTE: Tips should be installed **finger tight**. Do not attempt to tighten further, as damage to the indicator's internal mechanism may result.

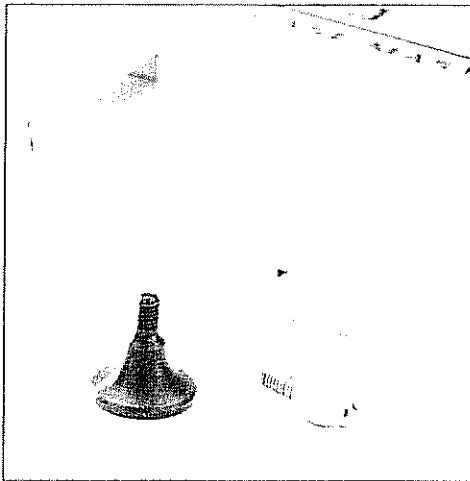

Photo #2

testing for case neck concentricity and bullet run-out. The rails allow the reloader to position the blocks to accommodate most cartridges.

Probe Stand

The probe stand is located on the left edge of the CaseMaster™ base. It is used when determining case neck thickness, and it holds the probe used to inspect fired cases for thinning.

V-Blocks

Two locking V-blocks are furnished with the CaseMaster™. They are mounted on a rail on the front edge of the base. These blocks are used for holding the cartridge case during

What is Accuracy?

Most of us know that accuracy is the ability of a rifle or handgun to place consecutive shots very close to one another. This ability is a function of the rifle, the ammunition, and the loading technique. The question often arises, "How much is good enough?"

The answer depends on the type of shooting you plan to do. For big game hunting, five-shot groups in the vicinity of one inch in diameter at 100 yards is excellent accuracy. This is adequate for large game at ranges beyond the marksmanship skills of most shooters. This level of accuracy can be attained in most bolt action and single shot rifles without any special loading techniques. Standard components, reloading equipment and techniques are capable of producing excellent game ammunition.

Varmint hunting, on the other hand, requires tighter groups. The targets are small and the ranges long. Most varmint hunters will want a combination of rifle and load which will shoot five-shot groups of 1/2 to 3/4 inch at 100 yards. Although conventional equipment and techniques can give that kind of accuracy, often a little extra effort is called for. Consistency in all aspects of handloading improves accuracy and the CaseMaster™ can help you inspect your cases for consistency.

For target shooting such as benchrest competition, accuracy requirements are severe. Here, the smallest group wins. In this game, "custom-made" is the key word. Rifles are hand-built with great care. Reloading dies often are custom-built to the exact dimension of the rifle's chamber. Bench rest shooters routinely use custom, hand-crafted bullets. A match may be shot with just a handful of carefully inspected and sorted cases. The measurements possible with the CaseMaster™ are an integral part of benchrest accuracy.

The point of this section is that you must have reasonable expectations of the accuracy of your equipment. The CaseMaster™ gauging tool can help you maximize the accuracy of a particular rifle, but that rifle has an absolute limit to its minimum possible group size. Once that limit is reached, no combination of components, loading equipment and techniques will cause any additional improvement. Be realistic in your accuracy expectations, and try to match those expectations to your equipment and particular shooting sport.

A Word about Measurements

There are two categories of measurements: absolute and relative. An absolute measurement gives the exact size (object "A" is exactly 1.238 inches long); the relative measurement gives a comparison (object "A" is 0.009 inches longer than object "B").

Dial indicators can do both, but are easier to use for relative measurements than absolute measurements. A micrometer or dial caliper is better suited for absolute measurements. The dial indicator can be used for absolute measurements within its range of travel if it is manually zeroed before taking the reading. The indicator furnished with the RCBS CaseMaster™ has a travel of 0.250 inches and reads accurately to .001". So, with proper zeroing, absolute measurements up to 1/4 inch can be made without additional gauges.

Since much of the measuring performed on a cartridge case is comparative, the dial indicator is excellent for this application. Most dimension comparisons that the reloader will read from the CaseMaster™ are relatively small, less than 0.010 inch. The dial indicator will allow quick, accurate measurement of these dimensions.

For certain measurements which exceed the range of travel of the dial indicator, a reference object of known dimension can be used to calibrate the major portion of the dimension. Then the readings from the dial indicator will be added or subtracted from the reference dimension. Clockwise motion of the pointer is a positive measurement,

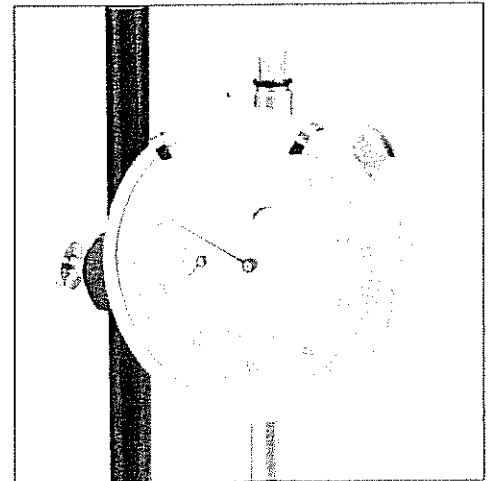

Photo #3

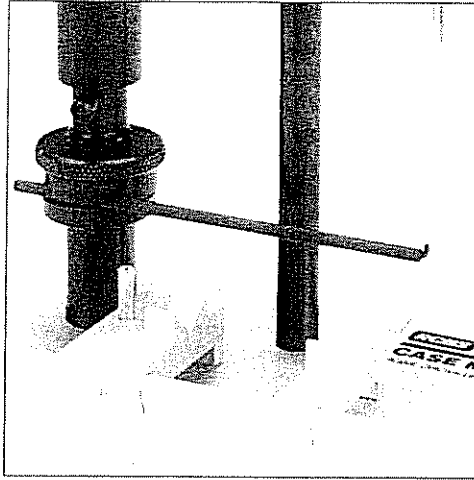

Photo #4

and would be added to the reference dimension. Counterclockwise motion of the pointer is a negative measurement, and would be subtracted from the reference dimension.

Each of the smallest divisions on the outer dial represents one-thousandth ($1/1000$) of an inch. The smaller scale located to the left of the larger pointer is calibrated in one-tenth ($1/10$) inch increments. See photo #3. A reading of 0.1 on the small scale and 22 (0.022 inches) on the main dial will add up to 0.122 inches.

Using the CaseMaster™

Before beginning, make sure that all preservative oils are removed from the surfaces of the case neck pin on the probe stand, the case neck pin sleeve and the V-blocks. Failure to remove foreign material from these surfaces can cause inaccurate readings and shorten the life of these components. Use a soft dry cloth to clean the face of the dial indicator. Cleaning solvents will damage the delicate plastic face. V-blocks should be installed on the mounting rail with the smaller block on the right and the large block on the left. See photo #4.

Take a moment to examine the dial indicator and its mount. The indicator is attached to an adjustable bracket to permit positioning it for different operations. Changing position will be required to accomplish all the different measurements possible with the CaseMaster™. See photo #5 and photo #6.

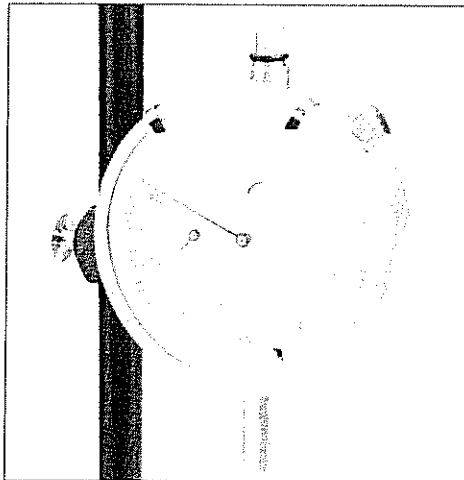

Photo #5

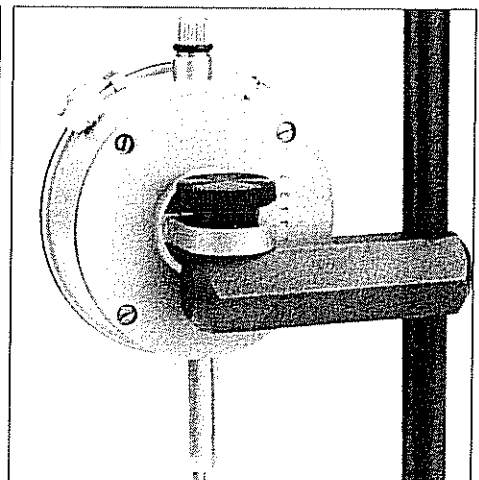

Photo #6

Testing for Run-out

Run-out is the measured indication of an out-of-round condition. This out-of-round condition means the case neck and/or the bullet are not concentric with the case body. In ammunition, the case itself may have run-out before loading. After loading, the bullet may have run-out if not properly seated, or if seated in a case which has neck run-out. Run-out can result from the manufacturing of a case, the chamber of a firearm or improper bullet seating. Typical case neck run-out of new factory brass is 0.002".

Case measurements will be most accurate when the case is clean. We highly recommend this operation, and that you perform the cleaning before proceeding. This will insure accurate readings and prolong the life of the contact surfaces on the CaseMaster™.

Case Neck Run-out Testing

First, position the dial indicator so that it is on the right side of the support rod and facing you. See that the ball tip is installed on the indicator. Loosen the thumbscrew on the small V-block and then loosen the thumbscrew on the indicator bracket. Move both the V-block and the dial indicator until the ball tip is pointing directly at the deepest point of the block. Adjust the height so that the tip is approximately even with the top of the block. After tightening the thumbscrew, make sure that the indicator has not shifted. If it shifts, loosen the thumbscrew and repeat until proper alignment is obtained.

Slide the small V-block to the left and lay a cartridge case in the block with the mouth pointing to the right. The small V-block should be positioned so that the case shoulder protrudes beyond the right edge of the block by at least 1/8 inch. Tip the case down so that the neck fits under the indicator tip. The case neck should be centered under the tip at its mid-point. See photo #7.

Now slide the larger V-block to a position under the head of the case. Gently press the case down so it contacts both V-blocks firmly while it compresses the indicator. Slide the larger block to the right until the stop pin contacts the case head. Check to see that the indicator tip is still touching the midpoint of the neck. When you are satisfied that the alignment is correct, tighten the thumbscrews to secure both V-blocks to the rail. The CaseMaster™ is now set for measuring neck run-out.

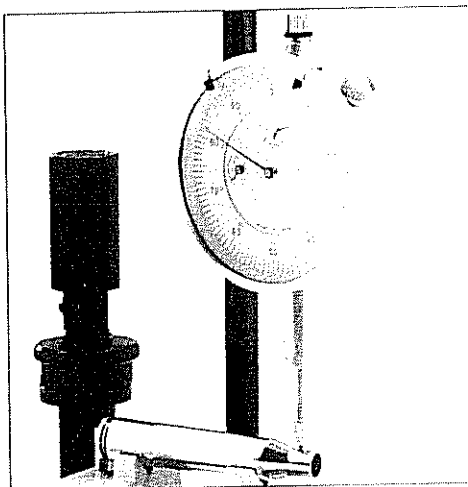

Photo #7

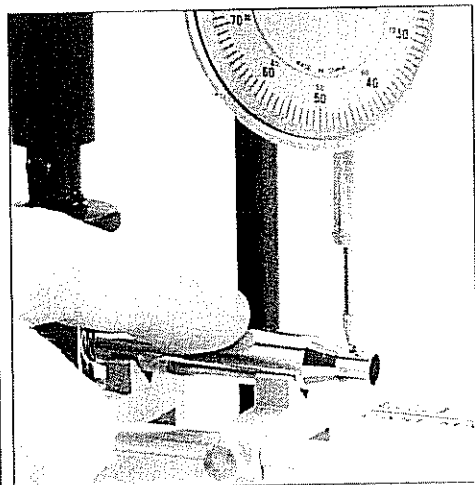

Photo #8

Using finger pressure to keep the case in contact with both V-blocks, slowly rotate the case and watch the dial indicator face. See photo #8. The pointer will move slightly as the case turns. Each small division on the dial equals one-thousandth (0.001) of an inch. Watch the dial to see how many divisions the needle passes while rotating the case. For example, if the pointer moves from 0.087 to 0.091, then the total run-out is 0.004 inches.

Run-out of 0.002" or less is typical of new factory brass and is considered OK. Cases which exceed this can either be set aside for non-critical use, or given corrective action. This will be discussed later in the section titled "Corrective Action" found on pages 13 and 14.

Bullet Run-out

Bullet run-out testing is quite similar to case neck run-out. Set up the CaseMaster™ in the same manner. However, when adjusting the V-blocks to accept the loaded cartridge, position the large (left) V-block so that the ball tip of the dial indicator touches the bullet approximately 1/10 inch ahead of the case mouth. See photo #9. Bullet run-out for factory ammo is typically 0.005" and that degree of run-out is adequate for most hunting ammo. Run-out of 0.003" or less is fine for varmint ammo. If bullet run-out is greater than 0.005", you should investigate the cause. Refer to "Corrective Action" on pages 13 and 14.

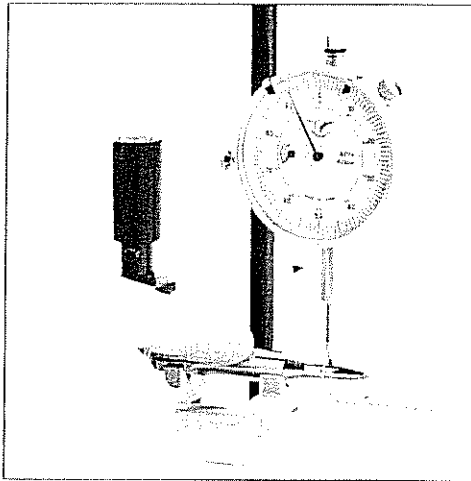

Photo #9

Testing for Case Neck Thickness

Case neck run-out can be due to variations in case neck thickness. Because of the forces used in case manufacturing, more metal may be present on one side of the neck than the other. This condition can sometimes occur from repeated firings. As with run-out testing, the case should be clean to get an accurate reading. Since the inside of the neck is supported during neck thickness testing, you should brush any powder residue from the case neck before proceeding. An RCBS case neck brush of the proper size will perform this task quickly.

To set the CaseMaster™ for neck thickness testing, loosen the thumbscrew and adjust the indicator bracket so that the dial indicator is positioned on the left side of the support rod with the dial facing forward. Check to see that the ball tip is installed in the dial indicator. Make sure the case neck pin sleeve is slipped over the probe stand and moves freely. The case neck pin sleeve is bevelled on one end and flat on the other. Be sure that the flat end is up. The bevelled edge should be touching the case neck pin, which protrudes from the side of the probe stand.

Loosen the thumbscrew on the indicator bracket and adjust the dial indicator so that the ball tip is resting on top of the case neck pin sleeve and compresses the indicator slightly. See photo #10. Tighten the thumbscrew. To verify that the tip is properly positioned, lift the case neck pin sleeve slightly. If correctly positioned, the dial pointer will move.

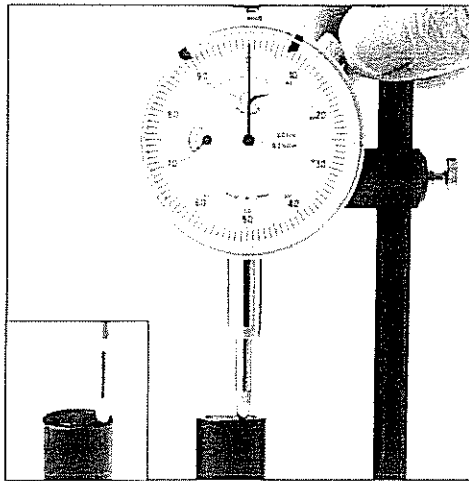

Photo #10

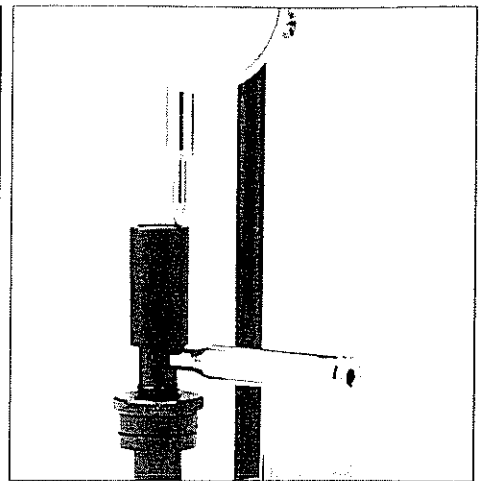

Photo #11

Case neck thickness is an absolute measurement. For accurate readings, zero the dial. Loosen the dial lock located on the indicator body at the two o'clock position. If the tally markers are installed on the dial face, you will need to unscrew the lock at least four full turns to clear the markers. Or, you can lift off the tally markers from the dial indicator. Rotate the dial so that the zero mark on the dial align exactly with the pointer. After tightening the dial lock, you are ready to measure cases.

Lift the case neck pin sleeve slightly with one hand, and slide the case mouth over the case neck pin. See photo #11. Lower the sleeve gently. Do not let the sleeve snap down, as damage to the case neck pin, sleeve and dial indicator may result.

Do not touch the CaseMaster™ or the cartridge case when taking a reading. The reading on the dial is the exact thickness of the case neck at the point where the sleeve contacts the neck. To assess the variation in neck thickness, rotate the case about one-sixth of a turn and take another reading. Notice that the dial will read high as you rotate the case. The reading will not be accurate until you release the case. Continue until the entire neck has been checked. You may wish to place a small mark on the case with a felt-tip pin to indicate the starting point. Record the range of readings. If variation greater than 0.002" is found, see the section, "Corrective Action".

Testing for Cartridge Length

The CaseMaster™ gauging tool can be used to quickly determine if a cartridge case has lengthened due to repeated firings. If the case exceeds the maximum permitted length, the neck may enter the throat of the chamber and cause excessive pressures. Best accuracy is obtained when all cases in a given lot are trimmed to the same length.

To use the CaseMaster™ to spot cases in need of trimming, set the dial indicator so that it is on the right side of the support rod. Install the flat indicator tip in the dial indicator. See photo #12. The position of the indicator is not critical, as long as a case can fit under the tip in such a way that it stands on a flat portion of the base.

Place the reference case that is the maximum length (this is a case that has been measured so you know the exact length of the case) for that caliber under the tip, mouth up. Lower the dial indicator tip onto the case mouth, compressing the indicator until the pointer is about at the

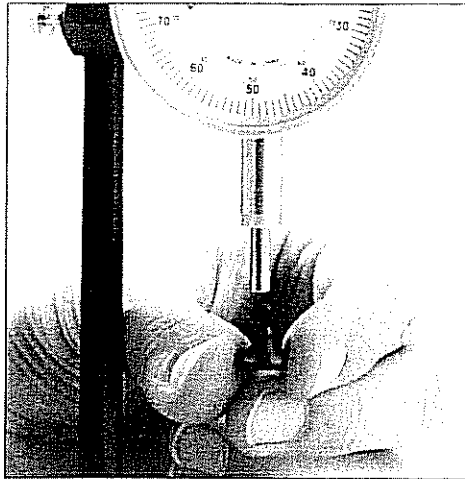

Photo #12

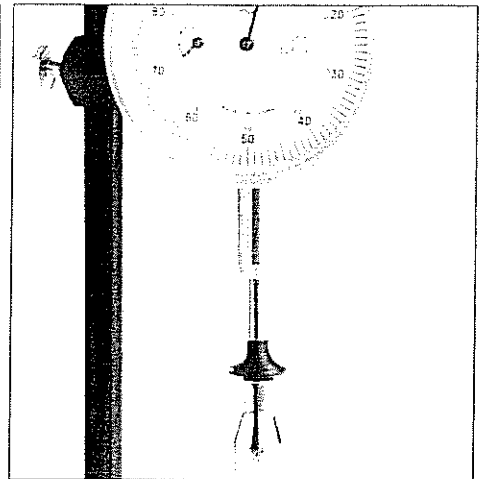

Photo #13

12 o'clock position. Tighten the locking knob to secure the indicator in this position. Loosen the dial lock and rotate the dial so that the zero mark is aligned with the pointer. Lock the dial.

Remove the reference case from the CaseMaster™. If the instrument is properly adjusted, the pointer will move counter-clockwise when the case is removed. Take a case to be measured and place it on the CaseMaster™ under the indicator tip. Lift the indicator spindle with your fingers to allow the case to fit. See photo #13. Look at the dial. If the case needs trimming, the pointer will have moved to the right of zero (clockwise). Cases which give a zero reading are at maximum and should be trimmed also. Cases which produce a reading to the left of zero (counter-clockwise) are under maximum and do not need trimming. Separate these cases from those that need to be trimmed.

For most rifle cases, trimmed length is 0.010 inch less than maximum. However there are exceptions. To make sure, consult the reference section of the Speer Reloading Manual. Also, mark the reference case as a length reference and keep it in the die box for that cartridge.

Testing for Case Head Separation

⚠ SAFETY NOTE: The probe used for this operation has a sharp point which can scratch or cut skin if contacted. When this feature is not in use, remove the probe and store it for future use.

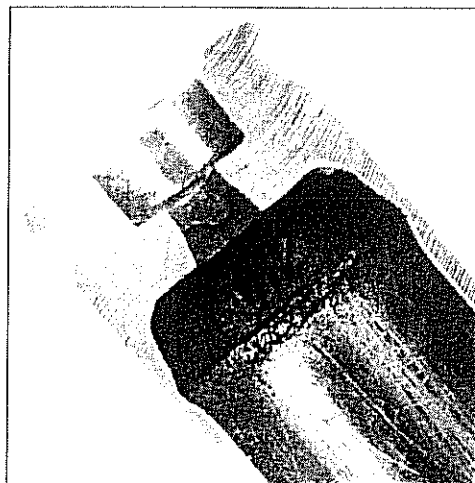

Photo #14

All cartridge cases stretch with repeated firings and resizing. See photo #14. Firearms with excessive headspace or incorrectly adjusted reloading dies will accelerate the process. With the CaseMaster™ gauging tool, it is possible to detect symptoms of case head separation before the condition becomes so bad as to show on the exterior of the case.

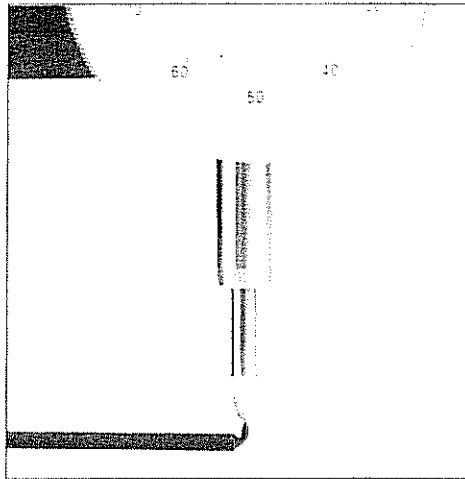

Photo #15

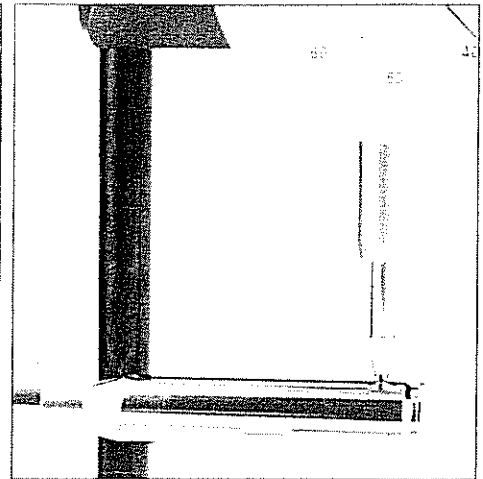

Photo #16

A probe with a hooked end is mounted to the probe stand. Loosen the knurled nut and rotate the probe, extending it so that the tip is in front of the CaseMaster™ and the hook is pointed up. Make certain that the probe is extended far enough so that the probe is longer than the case to be measured. Adjust the position of the dial indicator so it contacts the point of the probe with a slight compression of the indicator. See photo #15. Slide a fired case over the probe until the probe touches the bottom of the case. See photo #16. Drag the case over the hook tip so that the tip touches the inside of the case wall. If the case is sound, the indicator will smoothly unwind indicating a uniform taper in case wall thickness from the case head to the shoulder. A hesitation in the movement of the needle indicates uniform wall thickness resulting from normal stretching. If the direction of the needle travel stops or reverses momentarily, it indicates a crack in the wall is developing at that point and the case should be discarded.

If you find a case which shows symptoms of separation, destroy it by crushing it in a vise or with a pair of pliers. This way, weakened cases will not be accidentally mixed with good ones.

If you find a large number of cases which show this symptom after only one or two firings, you need to evaluate your sizing process and the condition of your firearm. If the shoulder on a bottleneck cases is pushed back more than necessary in the sizing die, case life will suffer. For popular calibers, the RCBS Precision Mic™ can be used to determine the correct sizing die adjustment for your rifle's chamber. By fitting the resized cases to your chamber, case life and accuracy will both benefit.

If a rifle has excessive headspace, there may be no way to correct for it through normal handloading techniques. The gun must be checked by a competent gunsmith or the manufacturer and corrected if needed. A set of custom dies may be required.

The type of action can make a difference in case life. Actions that lock at the rear of the bolt such as some lever actions and the Lee-Enfield bolt action may gauge correctly for headspace, but still shorten case life. These actions spring slightly as the firing pressure peaks, allowing the case to stretch. In these guns, you will have to accept shorter case life, and inspect cases for separations after each firing. Case life can be extended by avoiding maximum loads.

Corrective Action

Before taking corrective action, make certain that the case was clean at the time of the measurement. Otherwise, you may be working on a case which didn't need processing.

Case Neck Run-Out — New Cases

It is possible for factory new cases to exhibit run-out, although it is seldom enough to cause accuracy problems with any shooting activity other than bench rest competition. If the run-out exceeds 0.002", full length size the case in a standard sizing die and re-check run-out. This usually corrects the condition. If sizing does not correct the problem, skip to the section on run-out in sized fired cases to make sure your sizing procedure is sound.

Case Neck Run-Out — Unsized Fired Cases

It is possible that a firearm may not have a concentric chamber. If you determine that the case had no run-out prior to firing, but shows run-out after firing, this indicates that the neck portion of the chamber in your rifle is probably either out of round-not concentric with the chamber body-or is large enough to allow the neck to expand more on one side than the other. This condition should not cause any accuracy problems in a game rifle, and may not prevent getting good groups in a varmint rifle. Unless you cannot get good groups by any other means, corrective action is usually not indicated.

Case Neck Run-Out — Sized Fired Cases

If you detect excessive case neck run-out in a case which has just been sized, you need to check your sizing procedure. Use the following check list:

- Is the proper shell holder installed in the press?
- Is the shell holder properly seated in the ram?
- Is the sizer die firmly locked into the press?
- Is the expander ball spindle firmly secured to the die body?
- Is there excessive case lubricant on the case?

Normally, correcting these conditions will improve case neck concentricity.

Bullet Run-Out

Always check for case neck run-out before checking bullet run-out. A bullet seated in a case with excessive neck run-out cannot be expected to be free of run-out once seated.

If run-out greater than 0.005" is detected, here are things to check:

- Are you using the correct shell holder, and is it properly installed in the press?
- Is the seater die firmly locked in the press?
- Are you using a seater plug that fits the bullet? Using a round nose seater plug on a spitzer bullet can cause the bullet to tip during seating.
- Is the crimp shoulder striking the case mouth even though you don't plan to crimp? If so, back the die out slightly. (Always remember to use the seat plug for adjusting the bullet seating depth, not the die body).
- Are you using a smooth even stroke on the press during bullet seating? Jerking or rapid ram movement can cause poor bullet alignment.
- Is dirt or excessive powder residue present in the case neck?

For top varmint or bench-rest accuracy, a special seater die may be necessary. RCBS Gold Medal or Competition Die Sets include an in-line bullet seater die. The bullet is held in precise alignment with the case by a sliding sleeve within the die. It positions the bullet during the entire seating process. Standard dies, however, are capable of accurate bullet seating.

Case Neck Thickness Variation

New and once-fired brass may have minor variations in thickness that will disappear following sizing. Make sure the cases are free of grit and powder before testing. Thickness variations of less than 0.004" will generally not cause a problem in accuracy in most game ammunition unless it causes bullet run-out over .005". Varmint hunting ammunition may require that this be held to 0.002". For bench-rest competition, zero variation is preferred, and these rifles commonly have custom chambers with minimum dimensions. Such chambers call for custom fitted cases. Neck thickness variations can be corrected with an RCBS Case Trimmer with the RCBS Case Neck Turner accessory. The neck turner has a caliber specific pilot/cutter which reams the inside of the neck, and an adjustable cutter which turns the outside. For operating instructions, refer to the literature packaged with your case neck turner.

When turning case necks, regardless of the type of tool you use, remove as little metal as possible with each pass. This avoids damage to the cases, and will give more uniform results.

Customer Service

After reading this manual, if you have any questions or need additional help in using the Case Master™, call us at the factory. We'll be glad to help.

PARTS LIST

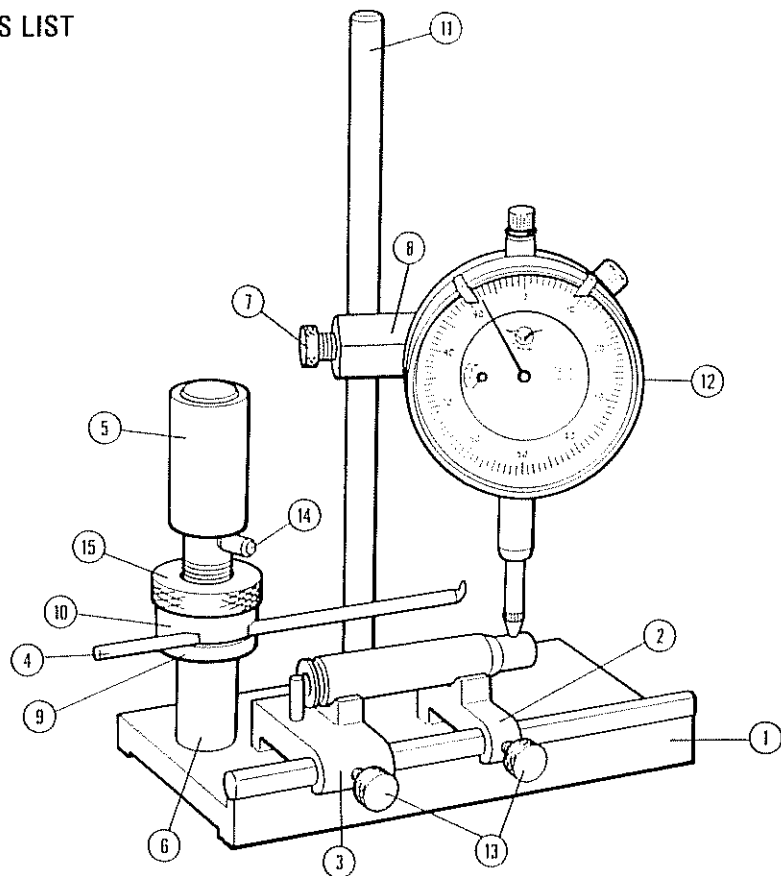

KEY	PART #	DESCRIPTION
1	7-87311	Base
2	7-87312	V-Block, Small
3	7-87313	V-Block, Large
4	7-87314	Probe
5	7-87315	Case Neck Pin Sleeve
6	7-87316	Probe Stand
7	7-87317	Thumbscrew, 10-32, Brass
8	7-87318	Indicator Adjustment Bracket
9	7-87320	Probe Retainer Sleeve
10	7-87321	Probe Retainer
11	7-87322	Support Rod
12	7-87327	Dial Indicator
13	7-87328	Thumbscrew, 8-32, Brass, 2
14	7-87329	Case Neck Pin
15	7-87331	Knurled Nut, 9/16-18

The following products are included with the CaseMaster but are not shown in the drawing.

-	7-87319	Thumbscrew, 1/4-20
-	7-87323	Flat Indicator Tip
-	7-87324	Flathead Allen Cap Screw, 2
-	7-87330	Accessory Base Plate Lock Down Screw, 2

RCBS[®]

PRECISIONEERED[®] RELOADING EQUIPMENT

*We think that we make the very best
reloading equipment in the world.
If you agree, please tell your friends.
If you disagree, tell us - we want to do something about it!*

Customer Service

1-800-533-5000 (US or Canada) or 530-533-5191

Hours: Monday - Thursday, 6:30am - 3:00pm (hours may vary)

e-mail: rcbs.tech@alk.com • www.rcbs.com

RCBS • 605 Oro Dam Blvd. • Oroville, CA 95965

CCI • SPEER • RCBS
OUTERS • RAMLINE • ORBEX • FEDERAL

7200514/0505